

## DYNAMIC RESPONSES OF RAILWAY ULTRA-HIGH-STRENGTH CONCRETE SLEEPERS UNDER EXTREME IMPACT LOADING

Sakdirat Kaewunruen<sup>1</sup>, Alex M Remennikov<sup>2</sup>, and Shintaro Minoura<sup>3</sup>

<sup>1</sup> Birmingham Centre for Railway Research and Education, School of Civil Engineering  
The University of Birmingham, Edgbaston, B15 2TT UK  
e-mail: s.kaewunruen@bham.ac.uk

<sup>2</sup> School of Civil, Mining and Environmental Engineering, University of Wollongong  
Wollongong, NSW Australia  
alexrem@uow.edu.au

<sup>3</sup> Structural Mechanics Laboratory, Railway Technical Research Institute  
Tokyo, Japan  
minoura.shintaro.51@rtri.or.jp

**Keywords:** Railway, Concrete Sleepers, Railroad Ties, Prestressing Tendons/Wires, Impact Analysis, Dynamic Responses, High Strength Concrete, Ultra High Performance, LS-Dyna.

**Abstract.** *Ultra high strength concrete has been adopted recently in construction industry. Prestressed concrete sleepers (or railroad ties) are designed usually using high strength concrete (around 50-80 MPa) in order to carry and transfer the wheel loads from the rails to the ground and to maintain rail gauge for safe train travels. The sleepers are installed as the crosstie beam support in railway track systems. They are subjected to impact loading conditions that are resulted from train operations over wheel or rail abnormalities, such as flat wheels, dipped rails, crossing transfers, rail squats, corrugation, etc. The magnitude of the shock load relies on various factors such as axle load, types of wheel/rail imperfections, speeds of vehicle, track stiffness, etc. This paper demonstrates the development of finite element modelling to investigate the dynamic responses of prestressed concrete sleepers using ultra high strength materials (over 100 MPa), particularly under a variety of impact loads. The 3D finite element model of prestressed concrete sleeper has been developed using a finite element package, LS-Dyna. It has been verified by the experiments carried out using the high capacity drop-weight impact machine at the University of Wollongong, Australia. The experimental results provide very good correlation with numerical simulations. In this paper, the numerical studies are extended to evaluate the dynamic behaviors of high strength steel wires and ultra high strength concrete; as well as their nonlinear responses under different parameters. The outcome of this study can potentially lead to the utilization and design guideline of ultra high strength concrete for prestressed concrete sleepers.*

## 1 INTRODUCTION

In ballasted railway tracks, railway sleeper is a major structural component to transfer train axle loads from the rails to the underlying ballast and supporting system. Typical ballasted railway track and its components can be seen in Figure 1 [1]. Reportedly, it is chronically believed based on the industry practice that railway concrete sleepers possess reserved strength that are untapped. Accordingly, it is essential to evaluate the spectrum and amplitudes of forces applied to the railway track, in order to understand more clearly the behaviors in which track components respond to those forces, and to identify the processes whereby concrete sleepers in particular carry those force actions. Recent findings show that the nature of the majority of loading conditions on track structures is of dynamic impact [2]. Those loads are normally of short duration but of very high magnitude. They are ascribed to the wheel/rail interactions associated with irregularities, i.e. wheel burns, wheel flats, corrugations, non-uniform track modulus, and any other out-of-round wheel defects. Structural performance monitoring is an effective way to establish better understanding into the impact behaviors of prestressed concrete sleepers.

In addition, cracks in concrete sleepers have been visually observed by many railway organizations. As described in the review [3], the principal cause of cracking is the infrequent but high-magnitude wheel loads produced by a small percentage of “bad” wheels or railhead surface defects. For instance, the typical loading duration produced by wheel flats is about 1-10 msec, while the force magnitude can be over 400 kN per rail seat. Existing structural design concept for prestressed concrete sleepers in Australia is based on permissible stress principle taking into account only the static and quasi-static loads, which are unrealistic to the actual dynamic loads on tracks. However, it is inevitable to avoid those criteria in any consideration of rail track designs since even the standard quality ride of rail vehicles still involves with the low-velocity impact forces. In order to devise a new limit states design concept whereas the extreme loading conditions can be taken into account, the research efforts are required to perform comprehensive studies of the loading conditions, the static behaviour, the dynamic response, and the impact resistance of the prestressed concrete sleepers [4]. A collaborative research task between the University of Birmingham and University of Wollongong is to evaluate the dynamic responses of concrete sleepers under static and impact loads. There have been only a few studies related to the modelling of prestressed concrete sleepers. Most of them predicted the rail seat flexural behaviour of the concrete sleepers [5-6] using high strength concrete of 50-60 MPa. In contrast, the use of ultra high strength concrete for manufacturing railway sleepers has not been thoroughly evaluated.

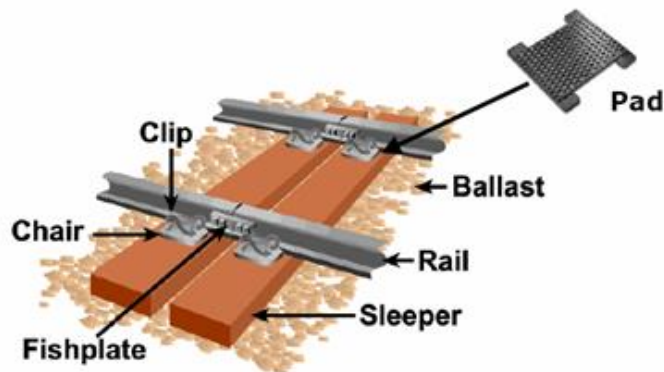

Figure 1: Typical ballasted railway track and its components [1]

This study has established a finite element model that can simulate and predict the responses of reinforced and prestressed concrete members. A three-dimensional non-linear finite element model of a railway prestressed concrete sleeper for static analysis was developed using the general-purpose finite element analysis package, ANSYS [7]. The concrete section was modelled using SOLID65 solid element where the compressive crushing of concrete and the concrete cracking in tension zone can be accommodated. In the current practice, the railway concrete sleeper is designed to resist prestressing force fully throughout the whole cross section as the force/moment redistribution can be seen in Figure 2. This makes the smeared crack analogy unsuitable for the replacement of prestressing tendons in the fully prestressed concrete sleeper. The use of a truss element, LINK8, for discrete reinforcement modelling, is then more practicable. An initial strain real-constant feature in ANSYS appropriately substituted the pre-tensioning forces in the tendon elements. However, it was assumed that perfect bonding between concrete and pre-stressing wires. The static full-scale experiment was conducted to validate this FE model [7]. The experimental details were based on the associated Australian Standards [8, 9].

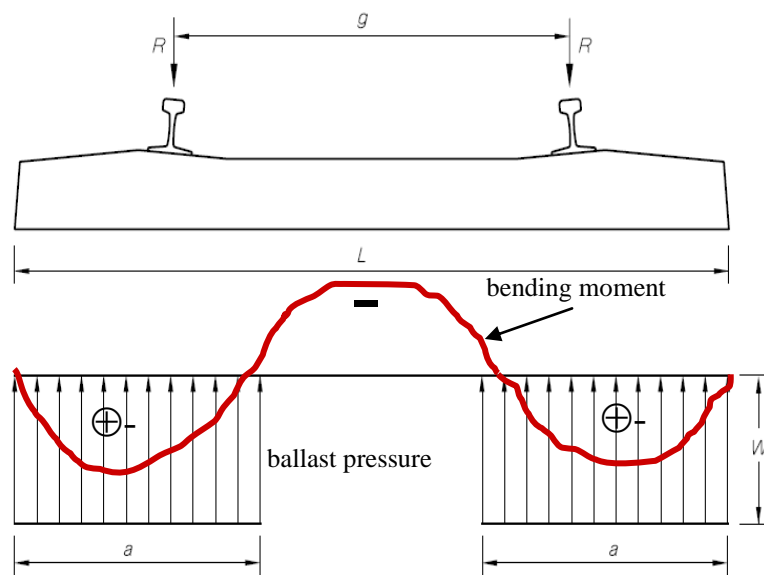

Figure 2: Moment distribution for standard gauge sleepers [8]

The calibrated finite element model has been extended to include ballast support and in situ boundary conditions. The extended model was linked to LS-Dyna [10] for impact analysis and validation against the drop impact tests. This paper investigates the impact responses of prestressed concrete sleepers using ultra high strength concrete (with compressive strength over 100 MPa). The highlights in this paper are the better understandings into the influence of concrete material on the impact behavior of railway prestressed concrete sleepers.

## 2 MODELLING OF IN SITU SLEEPER

In this investigation, the concrete part of the sleeper was modelled using a three-dimensional solid element, which has the material model to predict the failure of brittle materials [7]. This element is defined with eight nodes – each with three degrees of freedom: translations in nodal x, y, and z directions. To simulate the behaviour of prestressing wires, a truss element, were used to withstand the initial strain attributed to prestressing forces, by assuming

perfect bond between these elements and concrete. Note that this truss element cannot resist neither bending moments nor shear forces. Non-linear elastic behaviour of concrete can alternatively be defined by the multi-linear stress-strain relationships. The modulus of elasticity of concrete ( $E_c$ ) is estimated based on AS3600 [11] using the compressive strengths (100, 200, and 1000 MPa).

For prestressing wires, the bi-linear elasto-plastic material models can be used as well as the multi-linear isotropic model from the manufacturer's data. The 0.2% proof stress is 1,700 MPa and the ultimate stress is 1,930 MPa. The static and dynamic elasticity of moduli of prestressing wire are 190,000 MPa.

The multi-linear isotropic dynamic stress-strain curve for the concrete and prestressing wires can be calculated based on the consideration of the effect of strain rate. Based on the assumption of perfect bond between prestressing wires and concrete, the dynamic material properties of concrete and prestressing wires can be determined as follows [12].

*Concrete:*

$$\sigma = f'_{c,dyn} \left[ 2 \frac{\varepsilon}{\varepsilon_{c0,dyn}} - \left( \frac{\varepsilon}{\varepsilon_{c0,dyn}} \right)^2 \right] \quad (1)$$

$$\frac{f'_{c,dyn}}{f'_{c,st}} = 1.49 + 0.268 \log_{10} \dot{\varepsilon} + 0.035 [\log_{10} \dot{\varepsilon}]^2 \quad (2)$$

$$\frac{\varepsilon_{c0,dyn}}{\varepsilon_{c0,st}} = 1.24 + 0.053 \log_{10} \dot{\varepsilon} \quad (3)$$

where  $\sigma$  is the dynamic stress,  $f'_{c,dyn}$  is the dynamic compressive strength,  $f'_{c,st}$  is the static compressive strength of concrete,  $\varepsilon$  is the dynamic strain,  $\varepsilon_{c0,st}$  is the static ultimate strain, and  $\dot{\varepsilon}$  is the strain rate in concrete fibre.

*Prestressing wires:*

$$\frac{f_{y,dyn}}{f_{y,st}} = 10^{0.38 \log_{10} \dot{\varepsilon} - 0.258} + 0.993 \quad (4)$$

where  $f_{y,dyn}$  is the dynamic upper yield point stress,  $f_{y,st}$  is the static upper yield point stress of prestressing wires (about 0.84 times proof stress), and  $\dot{\varepsilon}$  is the strain rate in tendon.

A three-dimensional model of a typical railway prestressed concrete sleeper was developed initially in ANSYS [7] as illustrated in Figure 3. The dedicated solid bricks represent the concrete and the embedded three-dimensional spar elements are used as the prestressing wires. The pre-tensioning was modelled using an initial strain in the tendons corresponding to the prestressing forces at final stage (sustained prestressing force after all losses). For impact simulations, a FE model was extended to include rails, rail pads, ballast bed, and falling mass, as shown in Figure 4. The extended finite element model was calibrated using vibration data

[13-16]. The updated finite element model was then transferred to LS-Dyna. The simulation results were achieved by assigning the initial velocity to the drop mass to generate an impact event, similarly to the actual drop tests.

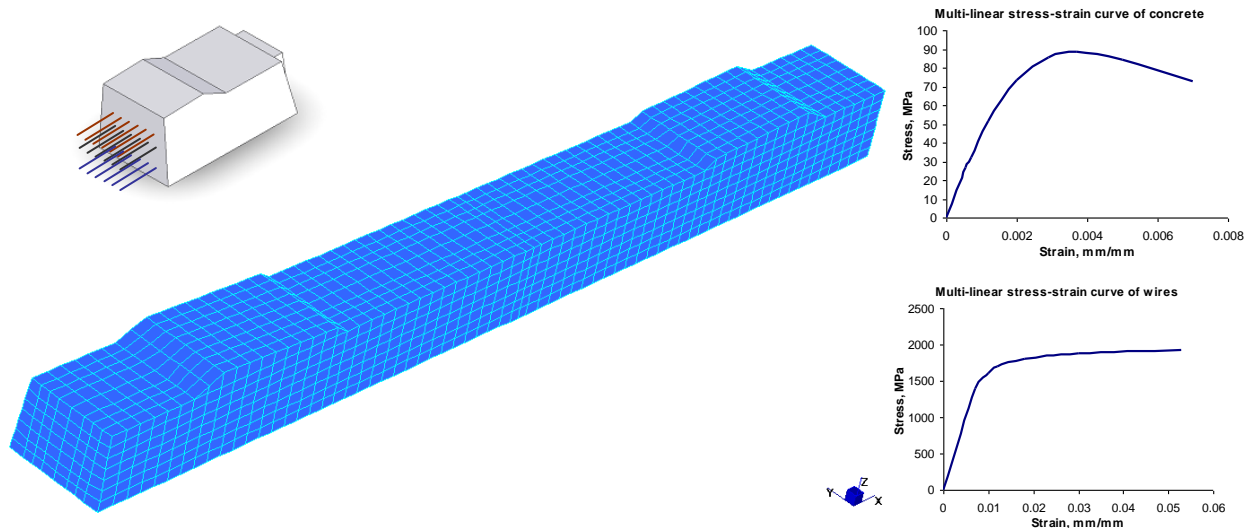

Figure 3: A three-dimensional model of full-scale railway sleeper [4]

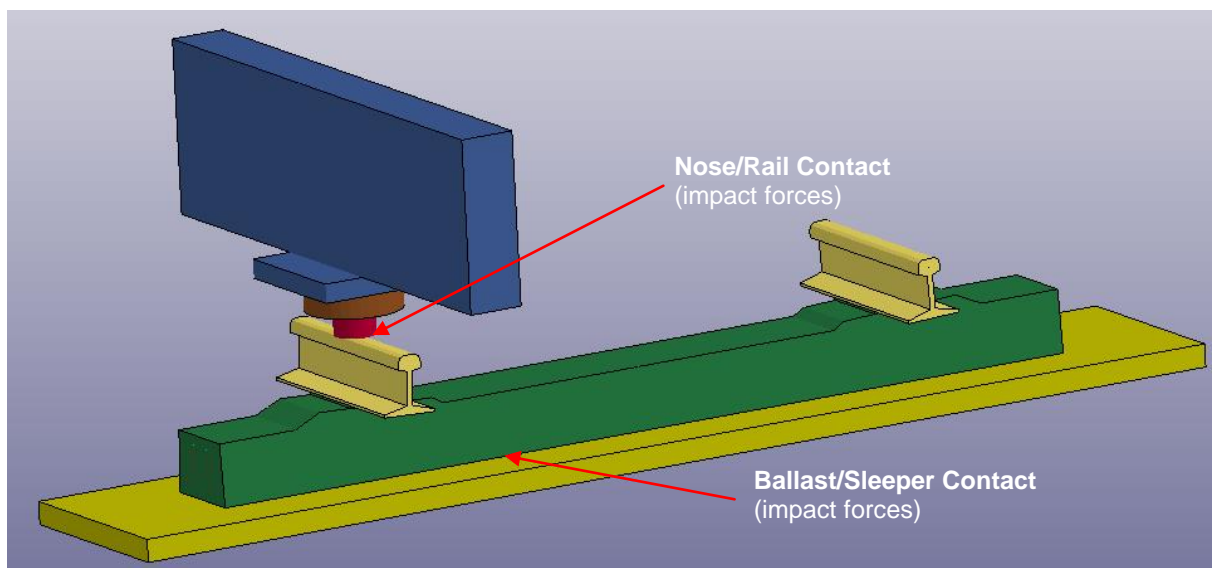
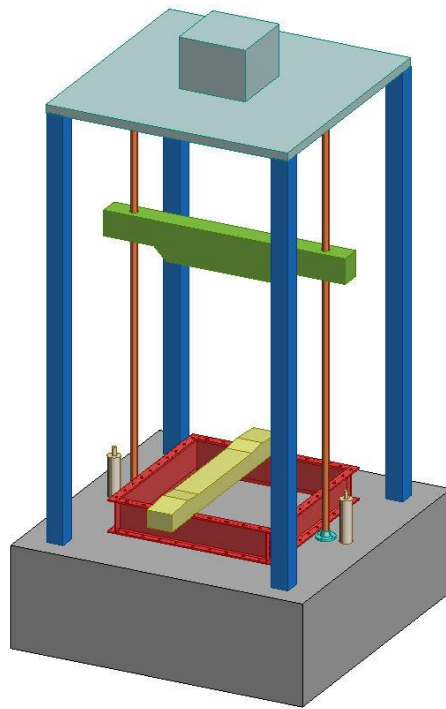

Figure 4: Extended finite element model of full-scale railway sleeper [4]

### 3 CALIBRATION OF FE MODEL

The prestressed concrete sleepers used in this study were kindly supplied by an Australian manufacturer, under a collaborative research framework funded by European Commission (H2020-RISE Project RISEN). A series of static tests on the concrete sleepers was performed at the University of Wollongong in accordance with the Australian Standards (which are similar to European Standards). The details of static responses, rotational capacity, post-failure mechanism, and residual load-carrying capacity of the prestressed concrete sleeper can be found in refs: [17-22].



a) sketch of impact machine



b) impact test setup

Figure 5: Experimental overview

The high-capacity drop-weight impact-testing machine has been developed at the University of Wollongong, as depicted in Figure 5a. The drop mass assembled is 5.81 kN with the varied height from 0 to 6m in total, which provide the maximum capacity of 10m/s drop velocities. Experimental setup and impact tests were arranged in accordance with the Australian Standards, as shown in Figure 5b. The accelerometers have been used to measure the dynamic responses at mid-span and railseat. The contact impact force between impactor and rail was recorded using the dynamic load cell connected to the data acquisition system. For the verification purpose, the drop height used was 0.1m since there was the measurement limitation for the accelerometers employed. The in-situ conditions of railway concrete sleeper were replicated. Attempts to simulate impact loading actually occurred in tracks were succeeded experimentally and numerically. Comparison between numerical and experimental results can be found in Figure 6. It is found that the finite element model is fairly sufficient for use in predicting impact responses of the prestressed concrete sleepers. The trends of peak acceleration responses are quite close to each other, although there is certain phase difference.

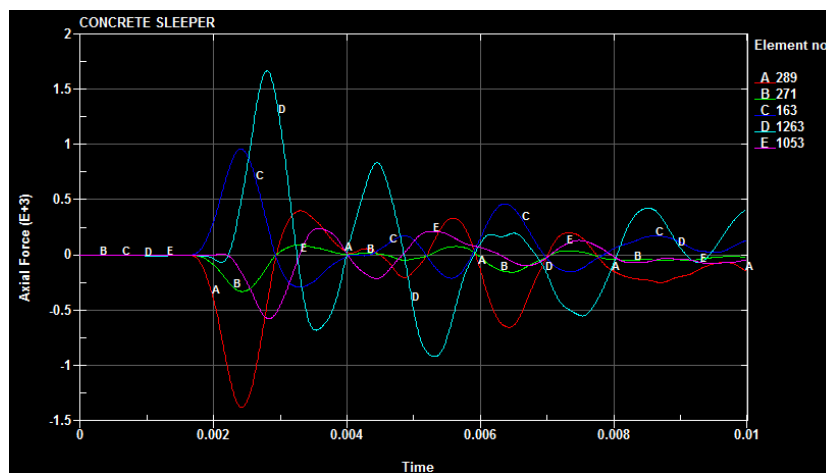
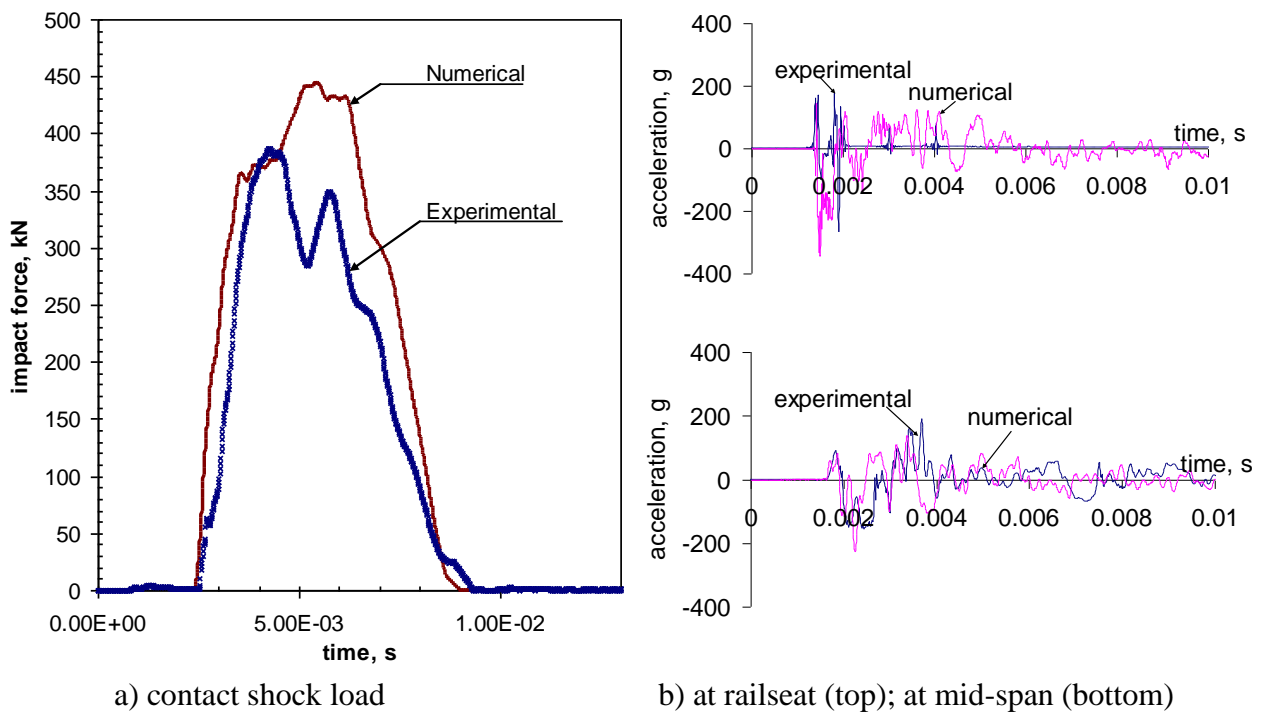

c) an example of prestressing force (at impact velocity 3 m/s)  
 Figure 6: Comparison of numerical and experimental results



#### 4 EFFECT OF ULTRA HIGH STRENGTH OF CONCRETE

The relationship between compressive strength and elastic modulus of concrete is a complex topic. As shown in Figure 7, the modulus of concrete can vary from 50GPa to 100GPa (depending on the type of concrete mixes). In this analysis, the modulus of 50 GPa, 80GPa, and 100 GPa are considered for benchmarking analysis. In the finite element model, the drop velocity is also varied to evaluate the effect of drop heights on the impact force occurring on railway track structures. On the other hand, this analysis provides the insight into the effect of railway track environments on the contact impact forces due to the identical causes and the responses of concrete sleepers to such loading. For example, a wheel, with 10mm wheel flat on a specific vehicle and running at 300 km/h, generates different contact impact forces on tracks with different environments. However, this study focuses only on concrete parameters as they play key role on the interface impact force characteristics and flexural responses of sleepers under a low-velocity impact [20] as illustrated in Figure 8.

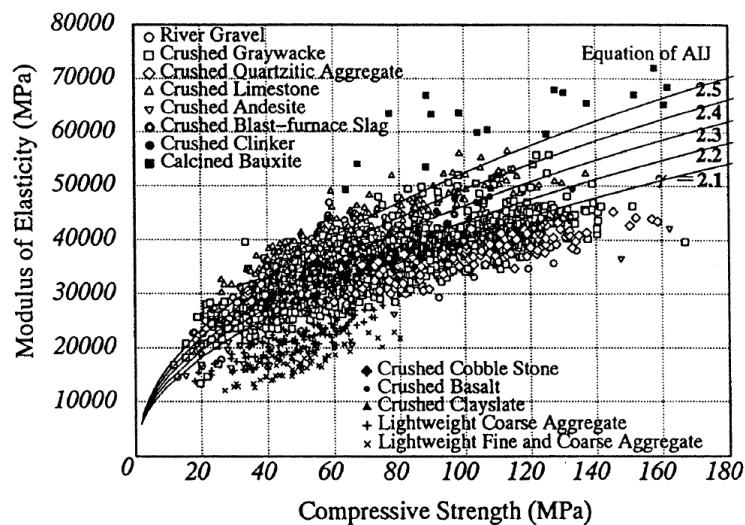

Figure 7: Compressive strength vs modulus of elasticity [22-25]

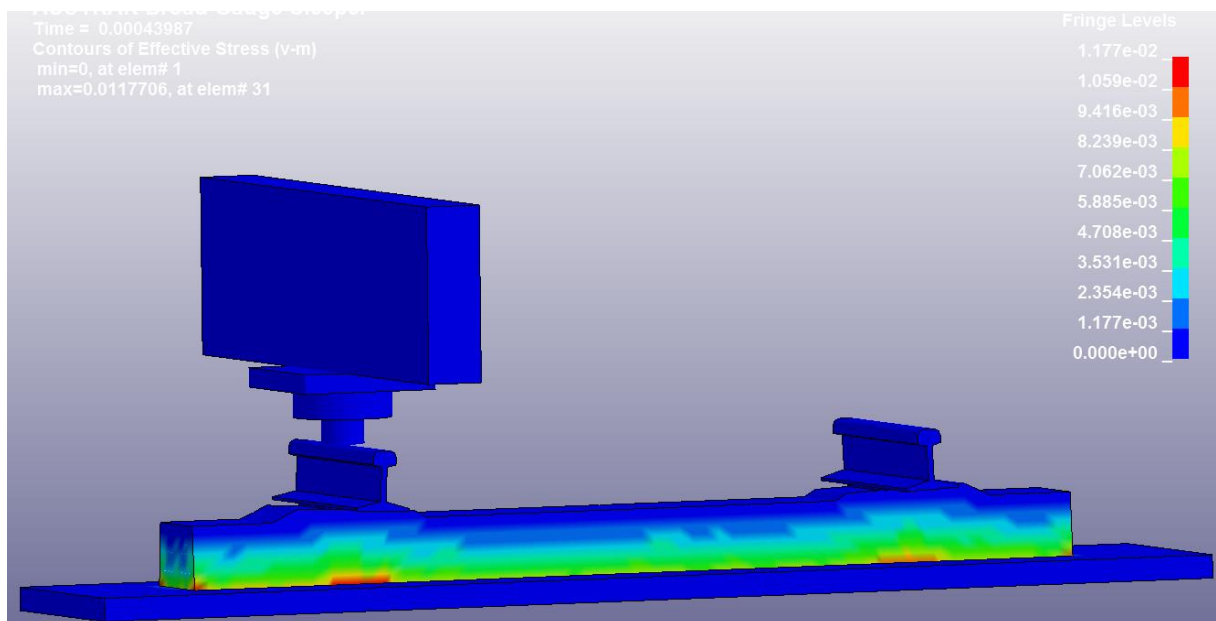

Figure 8: Impact von-mises stress in concrete sleeper (both railseats are firstly damaged)



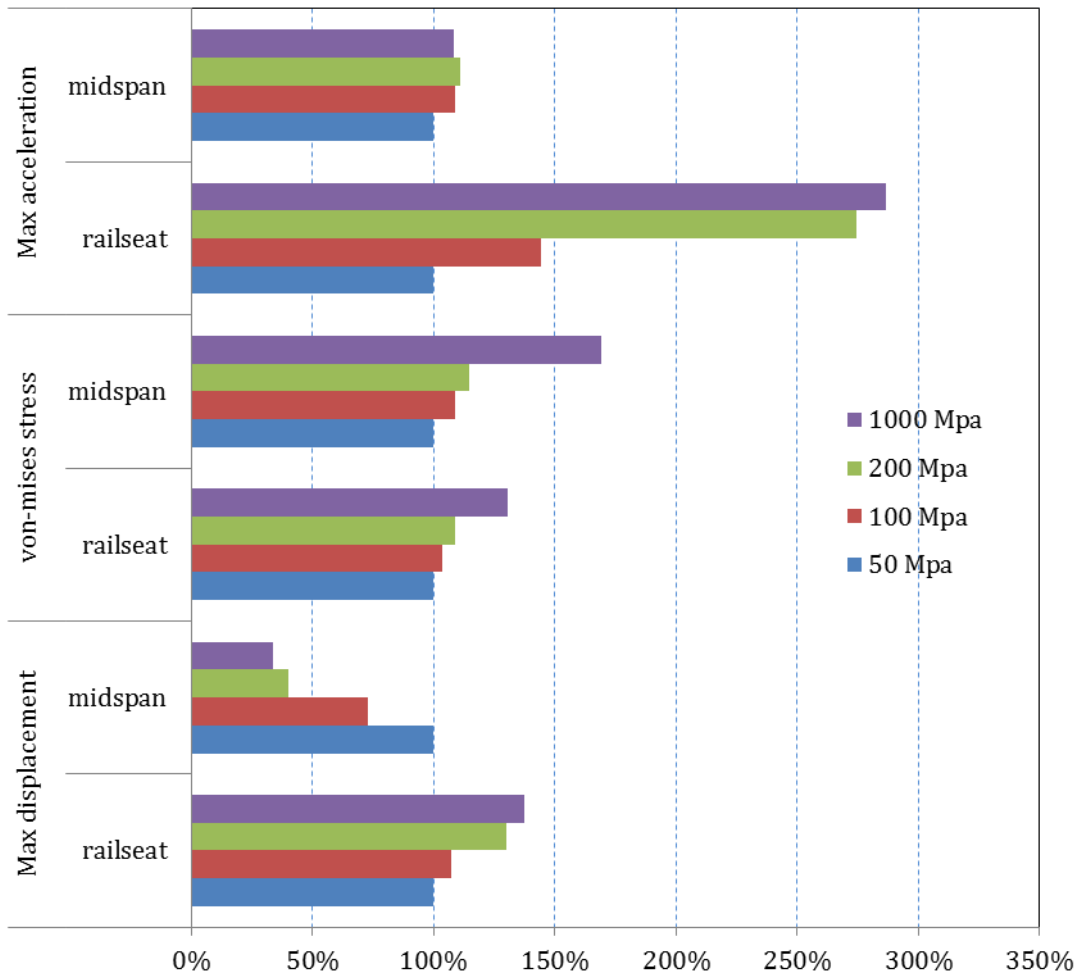

Figure 9: Effects of ultra-high-strength concrete on impact responses of railway sleepers

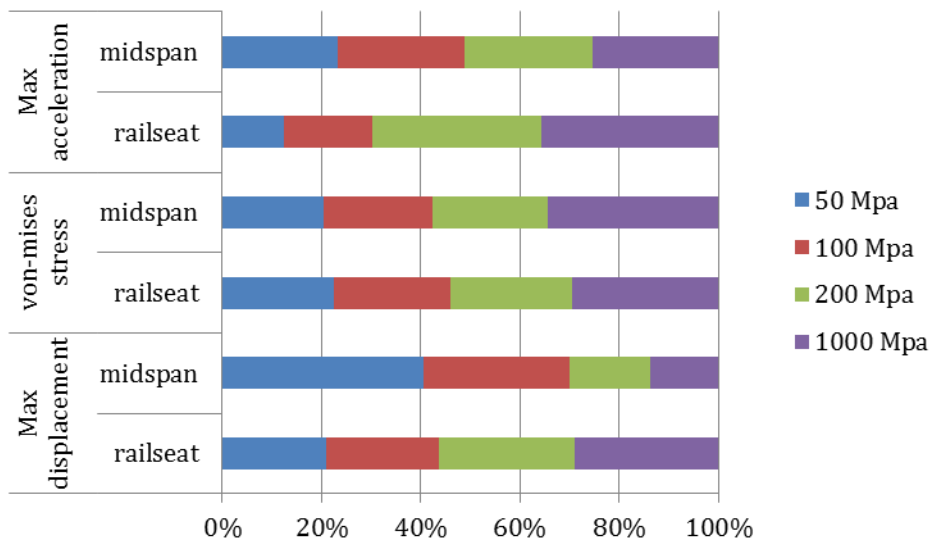

Figure 10: Influential analysis of ultra-high-strength concrete

Figures 9 and 10 demonstrate the dynamic effects of ultra-high-strength concrete on the impact responses of a railway sleeper. Using a normal high-strength concrete (50 MPa) as a baseline, it is clear that concrete strength plays an influential role in the maximum displacement, maximum acceleration and von-mises stress of the sleeper at both railseat and midspan zones. Especially at mid span, the von-mises stress can increase significantly due to the use of higher strength concrete. From Figure 10, it is clear that, in most cases, higher strength of concrete has more influence on the sleeper responses (except for the maximum displacement at mid span).

## 5 CONCLUSIONS

Ultra high strength concrete has recently been introduced in construction industry. Its application to railway environment has not been fully investigated. In this study, its use to manufacturing railway sleepers has been evaluated. The study is based on the experimental and numerical simulations of prestressed concrete sleepers subjected to impact loading. The three-dimensional finite element model have been established for investigate both static and dynamic behaviors of the railway sleepers. It has then been appended the track components to mimic in-situ conditions often found in actual tracks. A commercial finite element package, LS-Dyna, has been employed to extend the model for impact analysis and it has been validated against experimental drop impact tests. Nonlinear material properties under high strain rate effects were used. The emphasis of this study is placed on the effects of ultra-high-strength concrete on the dynamic responses of railway sleeper. This result illustrates dominant influences of concrete elastic moduli on the impact behavior of the sleeper. It is found that the ultra-high-strength concrete will increase stiffness of sleepers, then increase contact forces and dynamic responses of the sleepers.

## ACKNOWLEDGEMENT

The first author would like to gratefully acknowledge the University of Birmingham's BRIDGE Grant, which financially supports this work as part of the project "Improving damping and dynamic resistance in concrete through micro- and nano-engineering for sustainable and environmental-friendly applications in railway and other civil construction". This project is part of a collaborative BRIDGE program between the University of Birmingham and the University of Illinois at Urbana Champaign. The pre-stressed concrete sleepers were kindly provided by Austrak Ltd. The authors would also like to thank Alan Grant, Ian Bridge, Bob Roland, and Jason Knurst, for their assistance during the course of the experimental work. In addition, special thanks go to European Commission for financially sponsoring H2020-MSCA-RISE Project No. 691135 "RISEN: Rail Infrastructure Systems Engineering Network" ([www.risen2rail.eu](http://www.risen2rail.eu)).

## REFERENCES

- [1] Kaewunruen, S and Remennikov, AM, Non-destructive testing (NDT): A tool for dynamic health monitoring of railway track structures. *Materials Australia*, 39(6), 14-16 (invited), 2006.

- 
- [2] Remennikov, A.M. and Kaewunruen, S., A review on loading conditions for railway track structures due to train and track vertical interaction. *Structural Control and Health Monitoring*, 15, 207-234, 2008.
- [3] Murray, M and Cai, Z, Literature review on the design of railway prestressed concrete sleeper. *RSTA Research Report*, Australia, 1998.
- [4] Kaewunruen, S and Remennikov, AM, "Experimental and numerical studies of railway prestressed concrete sleepers under static and impact loads." *Civil Computing*, AIT-ACECOMS, inpress, 2007, (invited).
- [5] Gustavson, R, "Static and dynamic finite element analyses of concrete sleepers", *Licentiate of Engineering Thesis*, Department of Structural Engineering, Chalmers University of Technology, Sweden, 2000.
- [6] Gustavson, R, "Structural behaviour of concrete railway sleepers", *PhD Thesis*, Department of Structural Engineering, Chalmers University of Technology, Sweden, 2002
- [7] Kaewunruen, S and Remennikov, AM, "Nonlinear finite element modelling of railway prestressed concrete sleeper", *Proceedings of the tenth East Asia-Pacific Conference on Structural Engineering & Construction (EASEC-10)*, Bangkok, Thailand, August 3-5, 2006, Vol. 4, pp. 323-328.
- [8] Standards Australia, "Railway track material - Part 14: Prestressed concrete sleepers" *Australian Standard: AS1085.14-2003*, 2003a.
- [9] Standards Australia, "Railway track material - Part 19: Resilient fastening assemblies" *Australian Standard: AS1085.19-2003*, 2003b.
- [10] Livermore Software Technology Corporation, *LS-DYNA theoretical manual*. Livermore Software Technology Corporation, May 1998.
- [11] Standards Australia, "Design of concrete structures" *Australian Standard: AS3600-2001*, 2001.
- [12] Wakui H and Okuda H, "A study on limit-state design for prestressed concrete sleepers." *Concrete Library of JSCE* 33: pp. 1-25, 1999.
- [13] Remennikov, AM and Kaewunruen, S, "Determination of dynamic properties of rail pads using instrumented hammer impact technique." *Acoustics Australia*, 33(2), 63-67, 2005.
- [14] Remennikov, AM and Kaewunruen, S, "Experimental investigation on dynamic railway sleeper/ballast interaction." *Experimental Mechanics*, 46(1), 57-66, 2006.
- [15] Kaewunruen, S and Remennikov, AM, "Sensitivity analysis of free vibration characteristics of an in-situ railway concrete sleeper to variations of rail pad parameters." *Journal of Sound and Vibration*, 298(1-2), 453-461, 2006.
- [16] Kaewunruen, S and Remennikov, AM, "Effect of improper ballast tamping/packing on dynamic behaviors of on-track railway concrete sleeper." *International Journal of Structural Stability and Dynamics*, 7(1), 1-11, 2007.
- [17] Kaewunruen, S and Remennikov, AM, "Post-failure mechanism and residual load-carrying capacity of railway prestressed concrete sleeper under hogging moment", *Proceedings of the International Conference on Structural Integrity and Failure (SIF-2006)*, Sydney, Australia, September 27-29, pp. 331-336, 2006.

- [18] Remennikov, AM, Kaewunruen, S, and Ikaunieks, K, "Deterioration of dynamic rail pad characteristics." *Proceedings of Conference of Railway Engineering 2006*, Apr 30 - May 3, Melbourne, Australia, pp.173-179, 2006.
- [19] Kaewunruen, S and Remennikov, AM, "Monitoring structural degradation of rail bearing pads in laboratory using impact excitation technique." *Proceedings of the 1st International Conference on Structural Condition Assessment, Monitoring, and Improvement*, Dec 12-14, Perth, Australia, pp. 399-405, 2005.
- [20] Kaewunruen, S. and Remennikov, A., "Low-velocity impact analysis of prestressed concrete sleepers." *Concrete Institute of Australia's 23rd Biennial Conference 07*, October 18-20, Adelaide, Australia, 2007, [CD Rom].
- [21] Kaewunruen, S. and Remennikov, A., "Impact responses of prestressing tendons in railway concrete sleepers in high speed rail environments." *Proceedings of the 5<sup>th</sup> Computational Methods in Structural Dynamics and Earthquake Engineering*, May 25-27, Crete Island, Greece, 2015, [CD Rom].
- [22] Tomosawa, F., Noguchi, T., "Relationship between compressive strength and modulus of elasticity of high-strength concrete", *Journal of Structural and Construction Engineering* (Transactions of AIJ), 60(474), 1995.
- [23] Kaewunruen, S., Meesit, R., Mondal, P., "Early-age dynamic moduli of crumbed rubber concrete for compliant railway structures", *Journal of Sustainable Cement-Based Materials*, 2017, in press. doi: 10.1080/21650373.2017.1280425
- [24] Meesit, R., Kaewunruen, S., "Vibration characteristics of micro-engineered crumb rubber concrete for railway sleeper applications", *Journal of Advanced Concrete Technology* 15 (2), 55-66, 2017. doi: 10.3151/jact.15.55
- [25] Kaewunruen, S., Meesit, R., "Sensitivity of crumb rubber particle sizes on electrical resistance of rubberised concrete", *Cogent Engineering*, 3 (1), 1126937, 2016.